

CDMA Fixed Wireless Terminal User Guide

Model: LST-D400

REVISED HISTORY

DATE	ISSUE	CONTENTS OF CHANGES	REMARK
2002/09	ISSUE1	Initial Release	

Please read this manual before you use this product. This manual is based on the production version of LST-D400 FWT. Software changes may have occurred after this printing.
LGE reserves the right to make changes in technical and product specifications without prior notice.

FCC RF EXPOSURE INFORMATION

WARNING! *Read this information before using your phone*



In August 1996 the Federal Communications Commission (FCC) of the United States with its action in Report and Order FCC 96-326 adopted an updated safety standard for human exposure to radio frequency electromagnetic energy emitted by FCC regulated transmitters. Those guidelines are consistent with the safety standard previously set by both U.S. and international standards bodies. The design of this phone complies with the FCC guidelines and these international standards.



Use only the supplied or an approved antenna. Unauthorized antennas, modifications, or attachments could impair call quality, damage the phone, or result in violation of FCC regulations.

Do not use the phone with a damaged antenna. If a damaged antenna comes into contact with the skin, a minor burn may result. Please contact your local dealer for replacement antenna.

This device was tested for typical operations with the antenna of the device kept 2.5 cm. from the body. To maintain compliance with FCC RF exposure requirements, maintain a 2.5 cm. separation distance between the user's body and the device, including the antenna.

Table of Contents

1. Before You Start	6
1.1 Safety Information	6
1.2 Optimal Phone Performance.....	6
1.3 Care and Service.....	7
2. Introduction	8
2.1 Front, Side and Rear View of the Terminal.....	9
2.1.1 Mounting Template	10
2.2 3 LEDs Indicators	11
2.3 Installation	11
STEP I. Check Components.....	11
STEP II. Place the Terminal.....	12
STEP III. Connect Components.....	12
STEP IV. Check LED indicators.....	12
12121212122.4 Installation Steps	14
3. Basic Operation	15
3.1 Power On	15
3.2 Placing a call	15
3.3 Receiving a call	16
3.4 Ending a call.....	16
3.5 Warning Tone after Remote Disconnect.....	16
3.6 Emergency Call.....	16
4. System Features	17
4.1 Hook flash	17
4.2 ROH (Receiver Off Hook).....	17
4.3 Special Cellular Services.....	17
4.4 Applications	18
5. Programming	19
5.1 Speed Dial.....	19
Storing the Speed Dial Number.....	19
Enable or Disable Speed Dial	19
Operation.....	20
5.2 Emergency Call.....	20
Entering the emergency phone number.....	20
Enable or Disable emergency call.....	20
5.3 Hot Line	20
Programming the Hot Line number	20
Enable the Hot Line Feature	20
Disable the Hot Line Feature	21
Programming the Hot Line Time	21
5.4 Alarm	21
Entering Alarm Time (12-hour Mode).....	21
Entering Alarm Time (24-hour Mode).....	21
Disable Alarm Feature.....	21
5.5 Volume Level.....	22
Changing the Volume Level	22
5.6 Outgoing Call Lock.....	22
Enable or Disable Outgoing Call Lock	22
Changing Outgoing LOCK Code.....	22
5.7 G3 FAX Mode Setting	23
Enable or Disable G3 FAX mode (Only LST-D400).....	23

5.8	Restrict Call Mode Setting	24
	Set Restrict Call Level	24
	Storing the Permit Dial Number.....	24
	Storing the Deny Dial Number (Restricted dial number)	24
5.9	Buzzer On/Off Setting	25
	Boot up buzzer On/Off.....	25
	Warning buzzer On/Off	25
	Low battery buzzer On/Off	25
	Battery cut off buzzer On/Off.....	25
	Fading buzzer On/Off	25
	Voice message buzzer On/Off.....	26
	1 Minute buzzer On/Off	26
6.	Troubleshooting	28
7.	General Information	29
7.1	LST-D400	29

1. Before You Start

1.1 Safety Information

Warning

To reduce the risk of fire or electric shock, do not expose this product to rain or moisture. Do not use this product near swimming pools or other bodies of water.

IMPORTANT

Before installing or operating this product, read this information..

1.2 Optimal Phone Performance

- Do not operate your product when holding the antenna, or when someone is within four inches (ten centimeters) of the antenna.
Holding the antenna affects call quality and may cause the telephone to operate at a higher power level than needed.
- For the best call quality, keep the antenna free from obstructions and point the antenna straight up.
- Do not use the unit with a damaged antenna. Have your antenna replaced by a qualified technician immediately. Use only a manufacturer-approved antenna. Non-approved antennas, modifications, or attachments could impair call quality, damage the phone.
- RF energy may affect improperly installed or inadequately shielded personal medical devices such as pace markers, hospital monitor. Consult the manufacturer of any personal medical devices to determine if they are adequately shielded from external RF energy. Turn your terminal OFF in health care facilities when any regulations posted in the areas instruct you to do so. Hospitals or health care facilities may be using equipment that could be sensitive to external RF energy.
- If this equipment does cause harmful interference to radio or television reception, which can be determined by turning the equipment off and on, the user is encouraged to try to correct the interference by one or more of the following measures:
 - Reorient or relocate the receiving antenna
 - Increase the separation between the radio or television and the telephone.
 - Connect the equipment into an outlet on a circuit different from that to which the terminal is connected.
 - Consult you Authorized LG Dealer or an experienced radio/TV technician for help.
- Use only the battery, antenna and AC power supply provided by LG. Using any other type will invalidate the warranty.
- Only authorized personnel should service the phone and its accessories. Faulty installation or service may be dangerous and may invalidate the warranty.
- Do not use the unit in designated "no cellular phone use" area.

Avoid exposure to high temperature or humidity

- Avoid wetting the unit with any liquids. If the unit gets wet, turn the power off immediately and remove the backup battery and AC power supply. If the unit is inoperable, then return to the service agent for service.
- Avoid shock or impact.
- We recommend you to charge the backup battery before initial use. Backup battery may be discharged during delivery.
- This device complies with part 15 of the FCC Rules.
Operation is subject to the following two conditions:
 - This device may not cause harmful interference, and
 - this device must accept any interference received, including interference that may cause undesired operation.

1.3 Care and Service

- Unplug the Telephone from the wall outlet and remove antenna (or disconnect antenna cable) before cleaning. Do not use liquid or aerosol cleaners. Use a damp cloth for cleaning.
- If the unit fails for any reason, do not attempt to disassemble; contact the telephone service provider for assistance.
- If any of the following conditions exist: Unplug the unit at the wall plug, remove battery, and call the service provider.
 - The power supply cord is damaged or frayed.
 - Liquid has been spilled into the unit.
 - The unit has been exposed to rain or water.
 - The unit has been dropped or damaged.
 - The unit does not work normally by following the operating instructions.

2. Introduction

Congratulations on your purchase of the LG Fixed Wireless Terminal that has been designed to operate on the latest digital mobile communications technology, Code Division Multiple Access (CDMA). This CDMA digital technology has greatly enhanced voice clarity and can provide various advanced features. The terminal enables the normal operation and direct connection of standard telephone equipment into the cellular network.

The standard unit provides:

- A phone jack to plug in the telephone equipment (RJ-11 Port);
- Ring voltage used to ring the telephone connected to the unit, with a Ringer Equivalence Number of 4;
- A phone jack to plug in the G3 FAX equipment (RJ-11 Port);
- Data Port for service and repair(USB Port)
- AC Power supply with barrel plug connector;
- Support Dial tone;
- Touch tone (DTMF) or Pulse Dialing;
- Support Caller ID Telephone;
- Voice-Mail Notification ring alerts you to new voice-mail messages;
- Three lights (LEDs) to indicate the status of the unit;
- Dipole Antenna;

Some features can not be supported by service provider's equipment status.

For instance, the following features may not be supported ;

- Speed Dial
- Emergency Call
- Hot Line Call
- Alarm
- Outgoing Call Lock

Other features as determined by your service provider.

Note: Telephones with multiple terminating impedance should be set for 600ohms.

2.1 Front, Side and Rear View of the Terminal

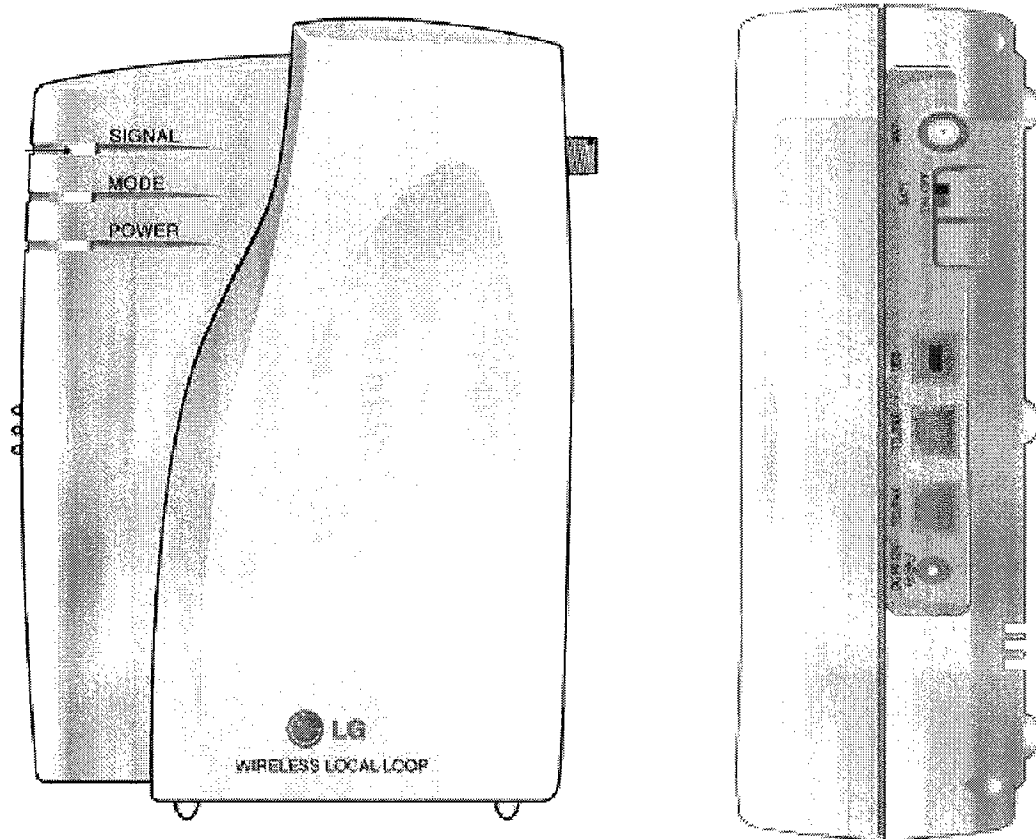

< Figure 1 >

ITEM	DESCRIPTION
① LEDs	Indicate the status of the unit
② DC IN 12V	AC/DC Power Adapter
③, ④ TEL/FAX (RJ-11 Port)	Connecting Ports for G3 FAX Machine or SLT (Single Line Telephone)
⑤ DATA Port (USB Port)	Connecting Port for Data Service to PC(USB)
⑥ Antenna Connector	Connecting Port for TNC Antenna

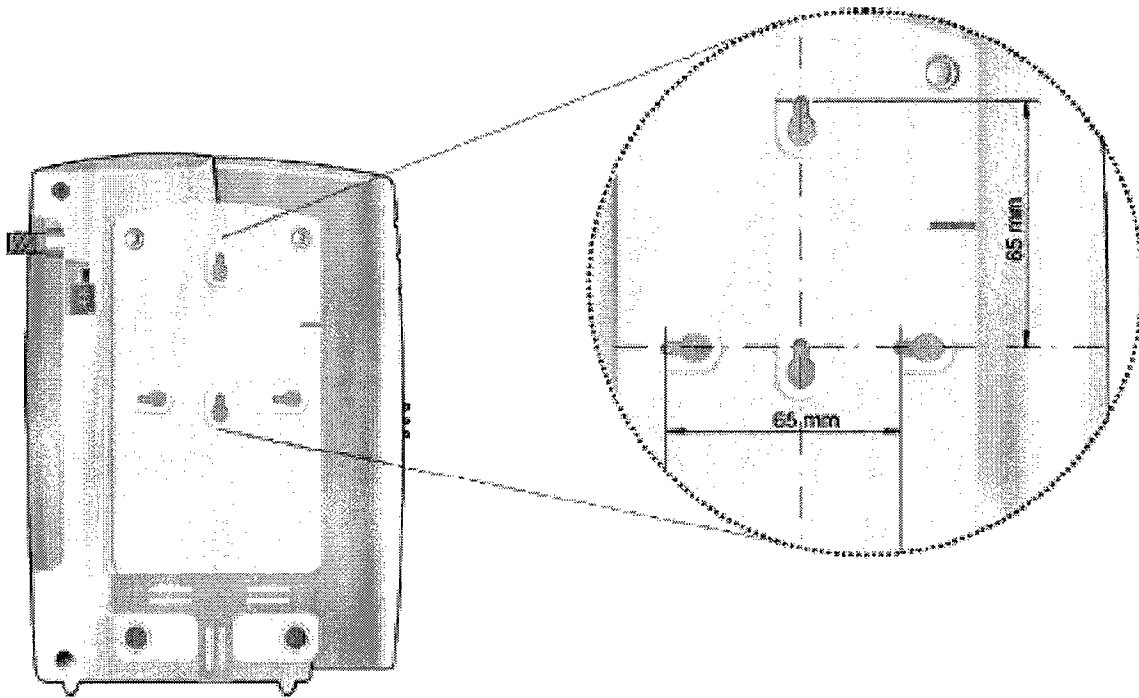

Mounting Template

2.1.1 Mounting Template

- To mount terminal on the wall, please follow the procedure to install it correctly.
 1. Determine suitable location to mount terminal with mounting template;
 2. Mark the two openings and select round or panhead type screw;
 3. Drill out the holes with drill bit smaller in diameter than the screws
 4. Secure two screws into the wall, leaving about 65mm gap between the screw heads and the wall;
 5. Insert the DC power pack into an electrical outlet and attach the telephone line into the Phone Jack (RJ-11) of the terminal.
 6. Place the terminal over the two screws so that the screw head protrudes out of the opening;
 7. Slide the terminal downward until the screw head is locked at the top of the opening and the terminal is secure;
 8. Tighten the screws the terminal is resting upon;

2.2 3 LEDs Indicators

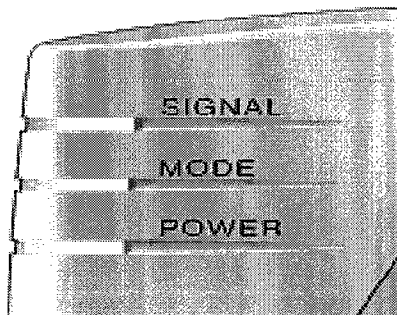

LED	COLOR	Operating Condition
POWER LED	GREEN-solid	DC Power is applied
	ORANGE-solid	Battery Power is applied
	RED-solid	Low Battery
SIGNAL LED	GREEN-solid	Good Signal
	ORANGE-solid	Poor Signal
	RED-solid	No Service Area
MODE LED	GREEN – blink (0.5sec On / 0.5sec Off)	Voice Message is received
	GREEN – blink (1 sec On / 1 sec Off)	Data Service or G3 Fax Service is working
	GREEN-solid	G3 FAX receive mode is enabled

[Table 1]

2.3 Installation

You should follow each step carefully as shown below in order to guarantee proper operation of CDMA Fixed Wireless Telephone.

STEP I. Check Components

- Fixed Wireless Terminal is supplied with the following standard unit and accessories;
 1. LST-D400 Unit -1 EA-
 2. Dipole Antenna -1 EA-
 3. Backup Battery -1 EA-
 4. User Guide -1 EA-
 5. AC/DC Power Adapter -1 EA-
 6. AC Power Cord -1 EA-
- Please make sure that these components are present and check for evidence of shipping before you begin the unit installation.
- If components are missing or damage is found, contact your authorized LG distributor immediately.

STEP II. Place the Terminal

- Place the terminal on the stable flat secure surface area (desk, table, etc.). Avoid direct exposure to the sun lights and damp area.
- Read the **Safety Information** located at the first part of this document before you place the terminal.

STEP III. Connect Components

- Connect the Dipole antenna to the TNC connector located at the topside of the terminal. (See Figure 1 to locate the TNC connector.)
If you placed the terminal on the flat surface, bend the antenna up side.
- Connect your phone cord to the RJ-11C port located at the side of the terminal.
- Connect the battery cable to the DC battery connector at the side of the terminal.
 - Remove the battery compartment cover.
 - Connect battery to the connector.
 - Replace the battery cover.
- Connect the AC power supply cable to the DC input port located at the side of the terminal.
- If you use Data Service or PC FAX Service, connect your USB cable cord to the USB port located at the side of the terminal.
- If you use G3 FAX machine, connect your line cord of G3 FAX to the RJ-11 port located at the side of the terminal.(only LST-D400)

“ Refer to Connection Diagram with external equipment in Figure 2 “

STEP IV. Check LED indicators

- When you followed the installation instruction STEP I to STEP III, please check the LEDs for normal operation.
- When DC power is fed at the first time, LEDs will operate as follows:
After few seconds,
Power LED is GREEN, if AC/DC power is applied.
If receiving signal strength is strong enough, then SIGNAL LED is GREEN,
If not, it is ORANGE or RED.
And MODE LED is turned off.

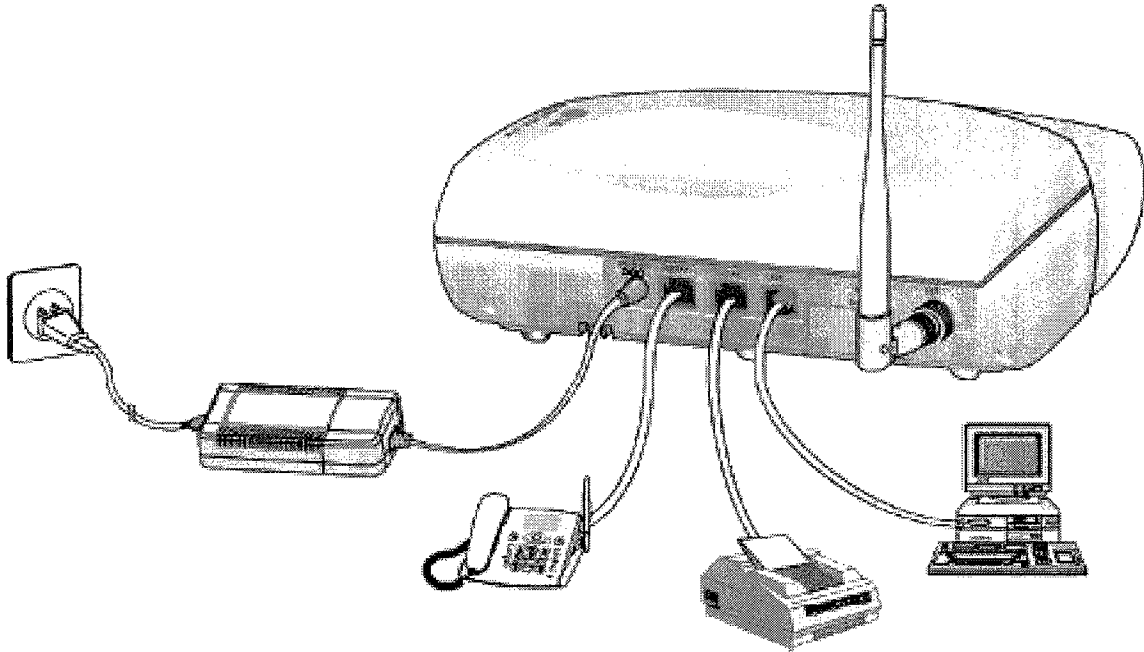

[LST-D400]

[Figure 2. Connection Diagram with External Equipment]

*** Note :**

- Length between LST-D400 and Telephone : within 1m.

※ The adapter type(with power cord) may be different by country adaptation.

2.4 Installation Steps

Please follow the below procedure to install the unit properly.

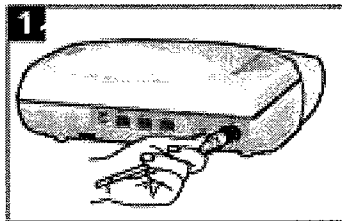

1 Connect the antenna to the TNC connector (Turn right).

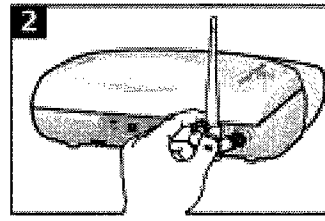

2 Bend the antenna up right.

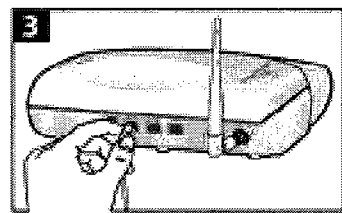

3 Connect your phone Cord.

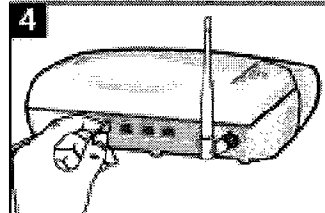

4 Connect the DC power supply.

Terminal Connection

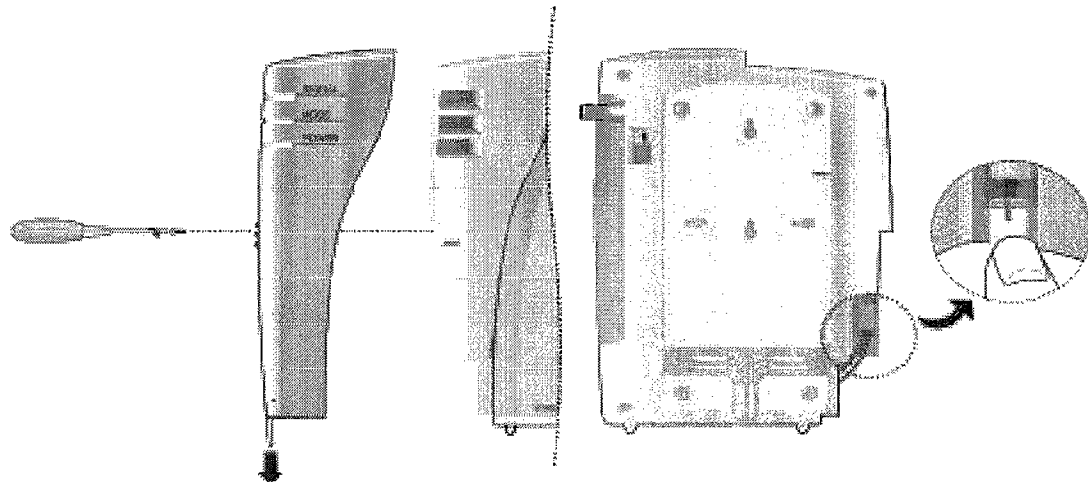

Battery Connection

- First, slow down the terminal' slide switch and unscrew.
- To connect battery, disassemble terminal like above figure.
- Battery connector's groove must be slid into the jack like above figure.

3. Basic Operation

3.1 Power On

1. The POWER LED indicates the presents status;
 - 1) Using AC Adapter : Solid Green
 - 2) Using internal battery : Solid ORANGE
 - 3) Using internal battery and battery is week capacity: Solid Red

2. When the terminal is succeeded in getting the service, SIGNAL LED indicates the strength of the signal(Table 1).
Lifting handset on telephone, dial tone is heard and you can enter a phone number.

Note :

- *) Not entering any key for 15 seconds warning tone will be produced.
 - *) In the overlap dial mode, it may take over 15seconds.
 - *) If Hot Line function is enabled, busy tone is not produced and hot line number is automatically connected.
 - *) While having maintenance request order or lock order from the system, neither dial tone nor busy tone is produced.
Instead of them, the lock tone("pi-pi-pi") will be heard one time and there will be no sound and both of MODE LED and POWER LED will be blinking with GREEN color simultaneously.
3. If the radio service is not available or radio signal is too weak to detect;
The SIGNAL LED is Red. (No Service status)

3.2 Placing a call

When lifting handset of the connected telephone ("off hook"), the terminal determines whether cellular service is available.

If it is available, dial tone is produced and a number can be dialed normally.

If phone service is not available, SIGNAL LED of the terminal will be red and no dial tone will be heard.

3.3 Receiving a call

The connected telephone rings when an incoming call is detected.
Pick up the handset and begin talking.

3.4 Ending a call

When you have completed the call, place the handset back on telephone. Also you can hook flash more than about 1 second to end a call and place a new call without hanging up the handset.

3.5 Warning Tone after Remote Disconnect

A warning tone may be heard in the telephone after a remote party hangs up from a call, allowing another call to be initiated after hook-flash.

3.6 Emergency Call

When emergency call number is connected once, it will not be terminated unless the called party disconnects the call (Emergency Call Hold Service).

Therefore even caller hangs up the telephone, the line will be still connected, so if the caller picks up the telephone again, he can continue talking.

If emergency call is connected, cellular service is not supported.

As long as your telephone is registered on a system, you can place a call to emergency number including 911-even if your telephone is locked* or restricted*.

Please check the available emergency call number with your service provider.

4. System Features

4.1 Hook flash

When the terminal receives a hook-flash from the connected telephone device, it will automatically allow:

1. For producing dial tone again after a phone number has been dialed without connection.
2. The use of special cellular services which may be available in your cellular service area.

Note: Hook-flash is accomplished in a call through either pressing the dedicated hook-flash key which is available on some phones or through a rapid single press of the hang-up mechanism upon which the handset rests when the phone is hung up.

4.2 ROH (Receiver Off Hook)

If the telephone equipment remains "off-hook", meaning that the handset is left off of its cradle as it would be when you hang up, with no dialing activity for about 30 seconds, a ROH tone emits from the receiver for a period of 30 seconds. after ROH tone, Line Lock Out Tone emits from receiver for a period of 30 seconds.

(In the overlap dial mode, above "30 seconds" or "60 seconds" may be different according to the system.)

(This feature may be available or not by country specification.)

4.3 Special Cellular Services

Many cellular systems offer special services such as call waiting, call forwarding, etc. You can purchase these services from your cellular service provider. There are certain dialing sequences to be entered, which vary from service provider to service provider. The service provider will provide the dialing instructions for your system.

Call Forwarding – An incoming call can be delivered to another telephone number programmed. Please contact your cellular service provider to use this feature.

Call Waiting – You can receive another incoming call during a call.

In this case, you will hear beep tone and then you can connect the second call holding the first call by entering a code required by cellular service provider.

Your cellular service provider may require hook-flash (a quick, simulated "hang up") to answer the waiting call. Other providers may require entering the codes involving digits 1-9, *, and # to answer a waiting call.

Three-way Conference Calls - For three-way conference calls, a hook-flash transmits the SEND command.

Please contact your cellular service provider for more information on using this service.

☞ Example

- ① Dial the first number and wait until connected;
- ② When connected, give hook-flash and dial the second number and give one more hook-flash to be connected;
- ③ When the second call is connected, give hook flash to complete a 3-way conference call.

Voice Mail – Use voice mail service in the same manner as you would on a regular telephone. If you have a new voice-mail message, the WLL-terminal transmits a special Voice-Mail Notification Ring (1sec On / 6sec Off default) and Mode LED is blinking (0.5sec On/0.5sec Off). Please contact your cellular service provider for more information on using Voice Mail or to change Voice-Mail Ring pattern.

Caller ID – LST-D400 can support Caller ID service if you have a telephone with Caller ID feature.

Please contact your cellular service provider for more information on using this service.

4.4 Applications

Data Communication - LST-D400 is capable of transmitting and receiving IS-707 Fax or modem communications.

For data communications, you will need a standard USB cable to connect your PC and FWT terminal. For further information, please contact our authorized service dealer.

Multi-extension Installations - For a multi-extension installation, make sure that all the extensions are on-hook.

If one extension is off-hook (not hung up), none of the extensions on that line will ring when a call is being received.

5. Programming

LST-D400 provides various convenient and various features to user. This chapter describes how to program these features and to use them. The followings are main features can be used;

Speed Dial
Emergency Call
Hot Line Call
Wake-up Alarm
Conversation Voice Level
Outgoing Call Lock
G3 Fax receive
Restrict Call

■ Programming Instruction

1. Lift Handset and press “#” key twice and you will hear the Menu Entering tone.
2. Enter the field number (1 ~ 8).
3. Press “#” key and you will hear confirmation tone.
4. Enter sub-fields and their options.
5. Press “*” key to save and you will hear confirmation tone.

Note :

As to the characteristic quality of some telephones, confirm tone or error tone could not be heard.

5.1 Speed Dial

LST-D400 has 30 memory locations (1~30:1 or 2 digits) to store frequently used phone numbers and you can make a call by pressing memory location number only when the speed dial feature is enabled.

Storing the Speed Dial Number

1. Press “#” + “#” + “1” continuously to enter speed dial programming mode.
2. Press “#” and one of memory numbers (1~30).
3. Press “#” and the phone number (Max. 32 digits).
4. Press “*” to store.

Enable or Disable Speed Dial

1. Press “#” + “#” + “1” continuously to enter speed dial programming mode.
2. Press “#” and “1” or “2” to enable or disable respectively.
“1” – Speed Dial Enable
“2” – Speed Dial Disable
3. Press “*” to store.

Operation

1. Make a speed dial function enable.
2. Lift handset and dial tone will be heard.
3. Press speed dial number and wait for dial timeout (5 seconds).

5.2 Emergency Call

LST-D400 has 3 emergency call numbers (1~3) and max. 32 digits can be stored in each emergency call number.

Entering the emergency phone number

1. Press “#”+“#”+“2” continuously to enter emergency call programming mode.
2. Press “#” and one of the emergency memory location numbers (1~3).
3. Press “#” and the phone number (Max. 32 digits).
4. Press “*” to save and enable this function.

Enable or Disable emergency call

1. Press “#”+“#”+“2” continuously to enter emergency call programming mode.
2. Press “#” and Enable code (“1”) or Disable code (“2”).
3. Press “*” to save.

Note :

If Emergency Call is disabled and Emergency Call number has been already programmed, you can make enable Emergency Call by pressing “#”+“#”+“2”+“#” + “1”+“*” without entering a emergency call number again.

5.3 Hot Line

While the Hot line function is enabled, the programmed number will be automatically dialed when you pick up the handset and wait for the programmed hot line time (2~10sec) without any key press.

Programming the Hot Line number

1. Press “#”+“#”+“3” continuously to enter Hot Line programming mode.
2. Press “#” and Hot Line Enable code “1”.
3. Press “#” and Hot Line phone number (Max. 32 digits).
4. Press “*” to save and enable this function.

Enable the Hot Line Feature

1. Press “#”+“#”+“3” continuously to enter Hot Line programming mode.
2. Press “#” and Hot Line Enable code “1”.
3. Press “*” to save.

Disable the Hot Line Feature

1. Press “#”+“#”+“3” continuously to enter Hot Line programming mode.
2. Press “#” and Hot Line Disable code “2”.
3. Press “*” to save.

Programming the Hot Line Time

1. Press “#”+“#”+“3” continuously to enter Hot Line programming mode.
2. Press “#” and Hot Line time code “3”.
3. Press “#” and enter desired Hot Line time (2~10 seconds).
4. Press “*” to save.

Note :

If Hot Line is disabled and Hot Line number has been already programmed, you can make enable Hot Line feature by pressing “#”+“#”+“3”+“#”+“1”+“*” without entering a Hot Line Number again.

5.4 Alarm

If alarm feature is enabled, you will hear ring at the programmed alarm time every day for 1 minute.

Alarm does not ring on the state of hook off, conversation or no service.

Entering Alarm Time (12-hour Mode)

1. Press “#”+“#”+“4” continuously to enter alarm time programming mode.
2. Press “#” and alarm time code “1” for 12-hour mode.
3. Press “#” and alarm time (HHMM +am(“1”) / pm(“2”).
4. In the forenoon, time range is 0000~1159.
5. In the afternoon, time range is 1200~1259 or 0100 ~1159.
6. Press “*” to save and enable Alarm Time.

Entering Alarm Time (24-hour Mode)

1. Press “#”+“#”+“4” continuously to enter alarm time programming mode.
2. Press “#” and alarm time code “2” for 24-hour mode.
3. Press “#” and alarm time (HHMM). (0000~2359)
4. Press “*” to save and enable Alarm Time.

Disable Alarm Feature

1. Press “#”+“#”+“4” continuously to enter alarm time programming mode.
2. Press “#” and alarm disable code “2”.
3. Press “*” to save.

Note :

If Alarm is disabled and time has been already programmed, you can make enable Alarm feature by pressing “#”+“#”+“4”+“#”+“1”+“*” without entering alarm time again.

5.5 Volume Level

There are three voice volume levels to be controlled by software, and you can set the level to the adequate conversation volume.

Changing the Volume Level

1. Press “#”+”#”+”5” continuously to enter Volume Level programming mode.
2. Press “#” and Volume Level (1~3),.
 - “1” – LOW Level
 - “2” – MIDDLE Level
 - “3” – HIGH Level
3. Press “*” to save.

Before pressing “*”, you can enter volume level continuously.

5.6 Outgoing Call Lock

If you try to make an outgoing call while outgoing call lock is enabled, then you will hear warning tone after dial time-out as a indication of entering the LOCK code. You should enter LOCK code to make an outgoing call. LOCK code is composed of 4 digits and the initial setting is “0000”. Outgoing Call Lock feature is disabled as a factory setting.

Enable or Disable Outgoing Call Lock

1. Press “#”+”#”+”6”+ continuously to enter Outgoing Call Lock programming mode
2. Press “#” and “LOCK code (4 digits)”
3. Press “#” and Enable (“1”) or Disable (“2”) code.
4. Press “*” to save.

Changing Outgoing LOCK Code

1. Press “#”+”#”+”6”+ continuously to enter Outgoing Call Lock programming mode
2. Press “#” and “LOCK code (4 digits)”
3. Press “#” and “3” to change LOCK code.
4. Press “#” and “new LOCK code (4 digits)”.
5. Press “#” and re-enter “new LOCK code (4 digits)”.
6. Press “*” to save.

5.7 G3 FAX Mode Setting

To activate a Data Fax call by G3 FAX connected to your LST-D400 terminal from the other devices (Land or Mobile Data Fax), your service provider should support wireless data FAX. And the LST-D400 mode should be changed to G3 FAX mode to change data path from USB to G3 FAX machine. Because the terminal doesn't recognize the call is for FAX or voice before being response. Following is the procedure to change data path and default data path is USB data path.

Once G3 Fax mode is set, if AC power is gone and turned on again, the saved G3 Fax mode value is restored

Enable or Disable G3 FAX mode (Only LST-D400)

1. Press “#”+”#”+”7” continuously to enter G3 FAX programming mode.
2. Press “#” and Enable (“1”) or Disable (“2”) code.

Enable means that Data call path is changed to G3 FAX.

Disable means that Data call path is changed to USB. (Default mode)

3. Press “*” to save.

Note 1. How to setup G3 FAX mode more easily

1. Press “#”+”#”+”7” continuously to enter G3 FAX programming mode.
2. Press Enable (“1”) or Disable (“2”) code.
Enable means that Data call path is changed to G3 FAX.
Disable means that Data call path is changed to USB. (Default mode)

Note 2. Sending or receiving some documents by G3 FAX is possible only in AC power mode. If AC power is gone, you cannot use the G3 FAX machine connected to the LST-D400.

Note 3. The recommended usage for this G3 FAX Mode is like this;

1. Disable G3 FAX Mode for normal usage.
 - You can make a voice call using the telephone device connected to the “TEL/FAX” Ports of the LST-D400.
 - You can FAX a document using the G3 FAX machine connected to the “TEL/FAX” Ports of the LST-D400.
2. To receive or send a document by FAX , should be set G3 FAX Mode. After receiving the FAX document, disable G3 FAX Mode for another voice call.
3. If you want to use the LST-D400 terminal only for G3 FAX sending or receiving other than the voice call, then keep the terminal in G3 FAX Mode enabled state.

5.8 Restrict Call Mode Setting

While the Restrict Call function is enabled, the specified numbers cannot be called. These specified numbers start with specific digits. The specific digits are set according to the following procedure (Storing the Deny dial number).

Among these specified numbers you can permit some numbers by designating start digits by following procedure (Storing the Permit dial number).

LST-D400 has 10 Deny dial numbers (1~10), and max. 32 digits can be stored in each Deny dial number.

LST-D400 has 10 Permit dial number (1~10), and max. 32 digits can be stored in each Permit dial number.

If you set Emergency call, the emergency number is not applied to this restrict call.

Set Restrict Call Level

1. Press “#”+”#”+”8”+ continuously to enter Restrict Call programming mode.
2. Press “#” and “LOCK code” (4 digits : set in Outgoing call lock / default is 0000).
3. Press “#” and restrict level (1~4)
 - “1” – No restriction
 - “2” – restriction
 - “3” – Emergency only (All excepting emergency are restricted.)
 - “4” – Clear restrict table
4. Press “*” to save

Storing the Permit Dial Number

1. Press “#”+”#”+”8”+ continuously to enter Restrict Call programming mode.
2. Press “#” and “LOCK code” (4 digits : set in Outgoing call lock / default is 0000).
3. Press “#” and “1” to enter Permit Dial Number store step.
4. Press “#” and one of “Memory number” for permit dial number(1~10).
5. Press “#” and the “digits” (Max. 32digits).
6. If you want to store more Permit Dial Numbers continue from step3
If you want to finish at this point, Press “*” to save.

Storing the Deny Dial Number (Restricted dial number)

1. Press “#”+”#”+”8”+ continuously to enter Restrict Call programming mode.
2. Press “#” and “LOCK code” (4 digits : set in Outgoing call lock / default is 0000).
3. Press “#” and “2” to enter Deny Dial Number store step.
4. Press “#” and one of “Memory number” for deny dial number(1~10).
5. Press “#” and the “digits” (Max. 32digits).
6. If you want to store more Deny Dial Numbers continue from step3
If you want to finish at this point, Press “*” to save.

5.9 Buzzer On/Off Setting

There are 7 buzzer types. These indicate boot up, poor signal area warning, low battery, battery cut off, fading, voice message, 1 minute from starting connect.

All type buzzer On/Off

1. Press "#"+ "#"+ "9"+ continuously to enter Buzzer On/Off programming mode.
2. Press "#" and all type buzzer code "0"
3. Press "#" and Enable ("1") or Disable ("2") code.
4. Press "*" to save

Boot up buzzer On/Off

5. Press "#"+ "#"+ "9"+ continuously to enter Buzzer On/Off programming mode.
6. Press "#" and boot up code "1"
7. Press "#" and Enable ("1") or Disable ("2") code.
8. Press "*" to save

Warning buzzer On/Off

1. Press "#"+ "#"+ "9"+ continuously to enter Buzzer On/Off programming mode.
2. Press "#" and poor signal area warning code "2"
3. Press "#" and Enable ("1") or Disable ("2") code.
4. Press "*" to save

Low battery buzzer On/Off

1. Press "#"+ "#"+ "9"+ continuously to enter Buzzer On/Off programming mode.
2. Press "#" and low battery code "3"
3. Press "#" and Enable ("1") or Disable ("2") code.
4. Press "*" to save

Battery cut off buzzer On/Off

1. Press "#"+ "#"+ "9"+ continuously to enter Buzzer On/Off programming mode.
2. Press "#" and battery cot off code "4"
3. Press "#" and Enable ("1") or Disable ("2") code.
4. Press "*" to save

Fading buzzer On/Off

1. Press "#"+ "#"+ "9"+ continuously to enter Buzzer On/Off programming mode.
2. Press "#" and fading code "5"
3. Press "#" and Enable ("1") or Disable ("2") code.
4. Press "*" to save

Voice message buzzer On/Off

1. Press "#"+ "#"+ "9"+ continuously to enter Buzzer On/Off programming mode.
2. Press "#" and voice message code "6"
3. Press "#" and Enable ("1") or Disable ("2") code.
4. Press "*" to save

1 Minute buzzer On/Off

1. Press "#"+ "#"+ "9"+ continuously to enter Buzzer On/Off programming mode.
2. Press "#" and 1 minute code "7"
3. Press "#" and Enable ("1") or Disable ("2") code.
4. Press "*" to save

6. Troubleshooting

In the event you are unable to place or receive telephone calls, first check the appropriate power indication on the LED. In case of no power, check the wiring connections between the power outlet and the terminal. Check for the appropriate service indication on the LED. If an adequate signal is not present, try different locations for the better signal reception.

This will verify the condition of the telephone equipment and the internal wiring of the telephone service to verify that it is working properly. If the telephone system of wiring is not working properly, replace or repair the equipment as required. The unit will not function with equipment that requires data transmission.

Contact your service provider if either of the following condition is true:

- The terminal does not work and the LED indicates “No Service” and if changing the locations does not resolve the problem.
- The terminal does not work and the LED indicates “In Service”.
- Power Supply – If the unit does not respond once plugged into a power supply;
 - Check that the AC power source.
 - Check that the Barrel Plug of the Power Supply is properly inserted into the terminal.
 - Check that the terminal Power Supply is properly plugged into the electrical outlet or power source.

Warning!

1. Only Authorized Service Personnel should remove the cover of the fixed wireless terminal for additional service. The contents of the terminal contain components that present an Electric Shock Hazard if handled improperly.

2. Using OHD button during ring-alert, you can hear a little noise on occasions.

3. According to the power condition, you can hear a little noise during connection.

For further assistance, contact your Authorized LG Distributor for service and assistance. Please keep your Model number and Serial number ready for quicker service.

7. General Information

7.1 LST-D400

- Main Unit

Item	Description
Tx Frequency	1850 ~ 1910 MHz
Rx Frequency	1930 ~ 1990 MHz
Channel Bandwidth	1.25 MHz
Frequency Stability	± 150 Hz
Tx Power	24dBm
Rx Power Level	-104 ~ -25 dBm
Size	210 x 150 x 63 mm
Weight(g)	620g (w/o battery) / 800g (w/ battery)

Item	Description
Input Voltage	100V ~ 280V AC
Input Frequency	50 / 60 Hz
Output Voltage	12V(DC) / 2A

Item	Description
Capacity	8.4V NiMH
Talk duration time	2 Hours
Standby duration time	24 Hours
Charging duration time	Within 24 Hours

Item	Description
Capacity	8.4V NiMH
Talk duration time	1 Hour
Standby duration time	12 Hours
Charging duration time	Within 24 Hours

Note : Talk duration time was measured at sector power -90dBm with 9600bps in Mobile test equipment. Standby duration time was measured at sector power -75dBm with Slotted mode(Slot Cycle Index 2)

Licensed by QUALCOMM Incorporated under one or more of the following Patents:

U.S, Patent No. 4,901,307 U.S, Patent No. 5,056,109 U.S, Patent No. 5,099,204
U.S, Patent No. 5,101,501 U.S, Patent No. 5,103,459 U.S, Patent No. 5,107,225